

*PATENTED
AND
DESIGN
REGISTERED*

Sovereign DUO

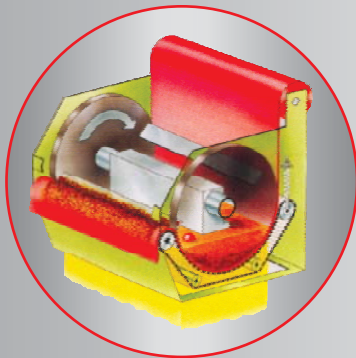

Kompakt Band Filter

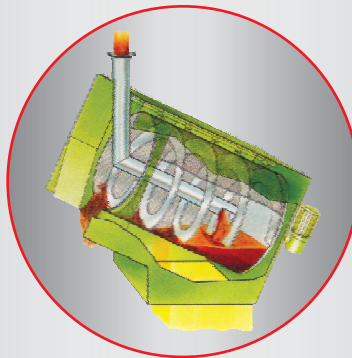

RolScreen Filter

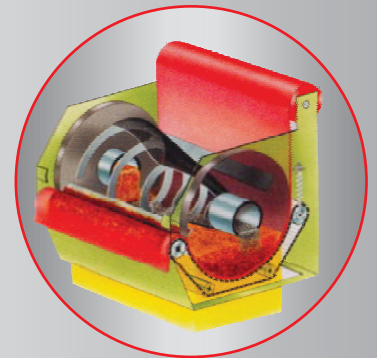

DUO

Designed for Clean and Green Machining

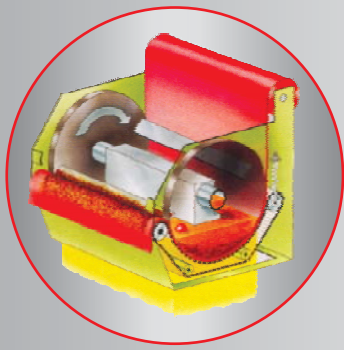

Kompakt Band Filter

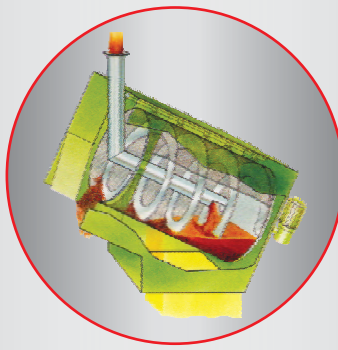

RolScreen Filter

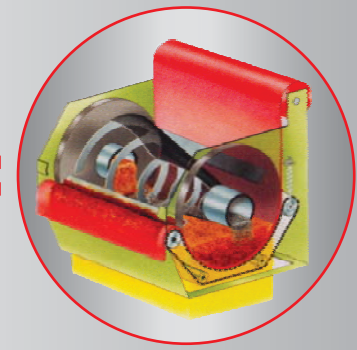

DUO

SovereignDUO is the perfect yet kompakt blend of Kompakt Band Filter + RolScreen Filter - the two efficient and equally established products for Coolant Filtration.

Construction & Operation

The SovereignDUO consists of continuously rotating 'Conical RolScreen Filter' at the centre into which the contaminated return coolant is discharged. The long and curly chips if any are separated by the 'Conical RolScreen Filter' and then discharged by the 'Discharge Screw' which rotates together with the 'Conical RolScreen Filter' by means of perfect frictional interlock. This facilitates efficient pre separation.

The mesh of the 'Conical RolScreen Filter' is continuously back flushed with the help of strategically placed 'Nozzle Holder' through which the optimal quantum of clean coolant is blasted for the drum back flush.

After this pre separation, the semi clean coolant drops down in to the semicircular filter basin for the super fine filtration through the Filter Media. This unique semi circular filter basin consists of 2 filter discs connected together with few sludge discharge blades and supported by the continuous Honey Comb Belt and the Filter Media. With the flexibility in adopting the filter media, customers can safely achieve the level of filtration fineness they desire and that too with no leakage nor a spillage.

Though a single integral unit, the 'Conical RolScreen Filter' and the 'Kompakt Band Filter' work independently of each other during the filtration process. This offers additional flexibility to fine tune the SovereignDUO to meet the incoming Chip load vis-à-vis to achieve the desired high coolant clarity. SovereignDUO is the culmination of customer centric engineering based on sound knowledge and expertise gathered over decades by RESY GERMANY our valued collaborator.

Customer Benefits:

- Efficient Solution for Long-Chipping materials
- Shop Floor Space Efficiency
- Smooth Trouble Free operation
- Minimal maintenance
- Brilliant Energy Efficiency
- Superb Resource Efficiency
- Excellent House Keeping
- Attractive ROI



Sovereign Tech
 ▲ PURE EXCELLENCE ▲

Sovereign Tech Engineering Services Pvt. Ltd.

Corporate:
 14, Mahinder Chambers, W. T. Patil Road, Chembur
 Mumbai 400 071, India
 Tel: +91 22 6797 3259/3260
 Fax: +91 22 6798 7499
 E-mail: corporate@sovereigntech.in

Marketing & Works:
 A-515, TTC Industrial Area, MIDC, Mahape
 Navi Mumbai 400 701, India
 Tel: +91-22-27781361 / 1365 / 1366
 +91-22-27783710 / 11 / 12 /13 Fax: +91 22 2778 1238
 E-mail: marketing@sovereigntech.in